

REVISION	DATE	DESCRIPTION	SIGNED
0	06/07/16	ORIGINAL VERSION	K.P.

FAST FORM BRACKET SYSTEM 1200MM BRACKETS - BASE

OVERVIEW
1:30

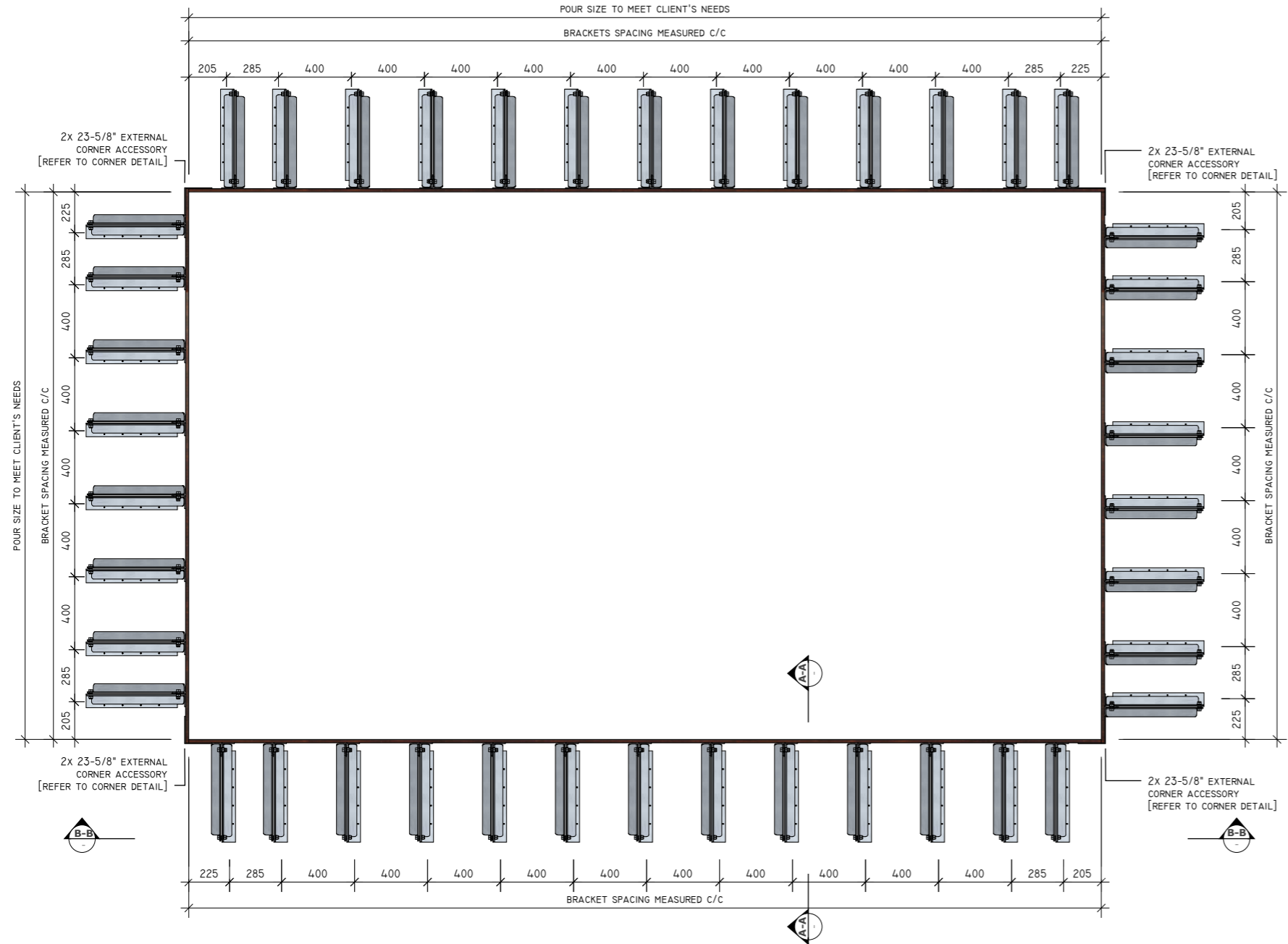

CORNER DETAIL
1:25

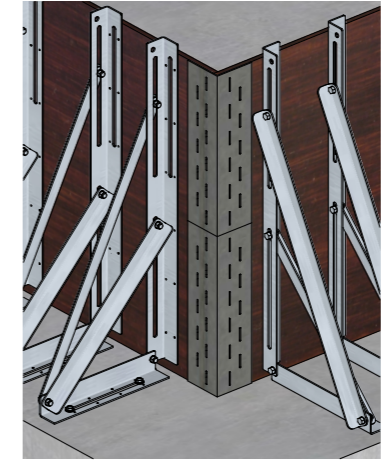

POSITION THE BRACKETS AS CLOSE TO THE CORNER ACCESSORY AS POSSIBLE

IMPORTANT:

- ALL DIMENSIONS IN INCHES UNLESS NOTED OTHERWISE.
- MINIMUM THICKNESS AND STRENGTH OF CONCRETE BLINDING FOR INSTALLATION OF CONCRETE BOLTS IS SPECIFIED IN THE PRODUCER'S TECHNICAL APPROVAL.
- ALL BOLTS TO BE TIGHTENED WITH A 110V IMPACT WRENCH!
- PLYWOOD TO BE MIN. 18MM EXTERIOR STRUCTURAL GRADE.
- POSITION THE PLYWOOD JOINTS TO FALL ON CENTRE OF THE BRACKETS.
- BRACKETS TO BE AT MAX. 400MM CENTRES.
- PLYWOOD TO BE FIXED TO THE BRACKETS FROM THE BACK WITH 25MM WOOD SCREWS.
- APPLY CONCRETE RELEASE AGENT / MOULD OIL TO FACE OF PLYWOOD PRIOR TO POURING CONCRETE.

A-A
1:10

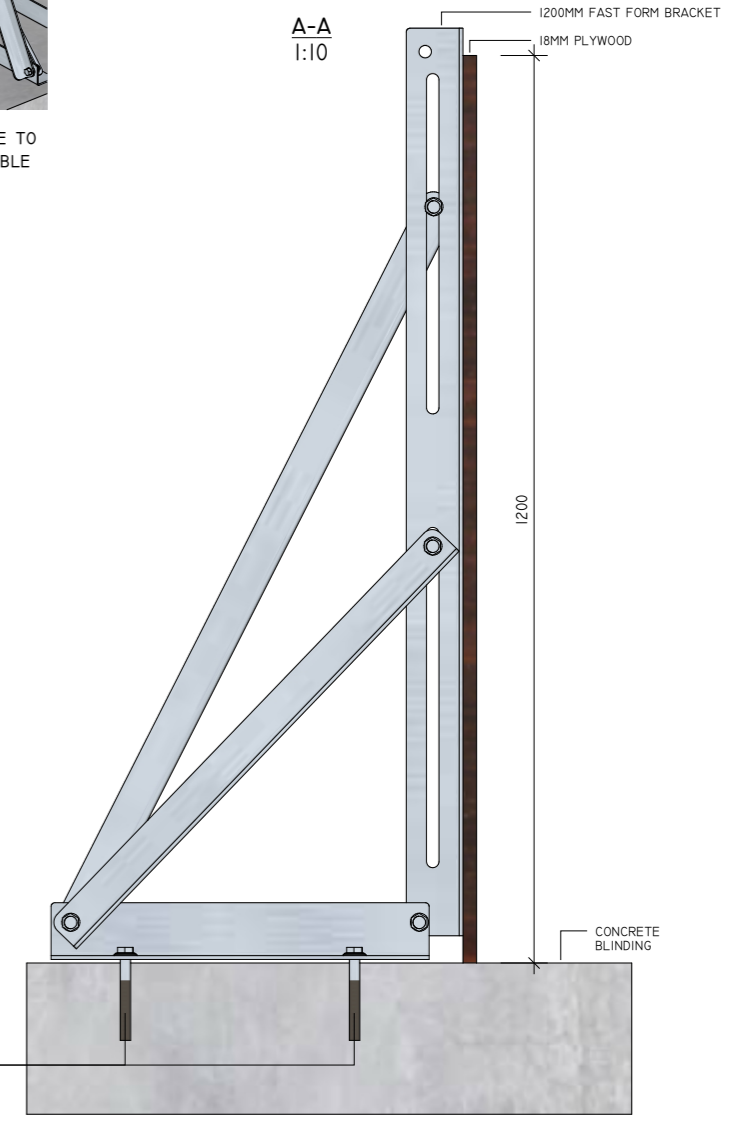

B-B
1:50

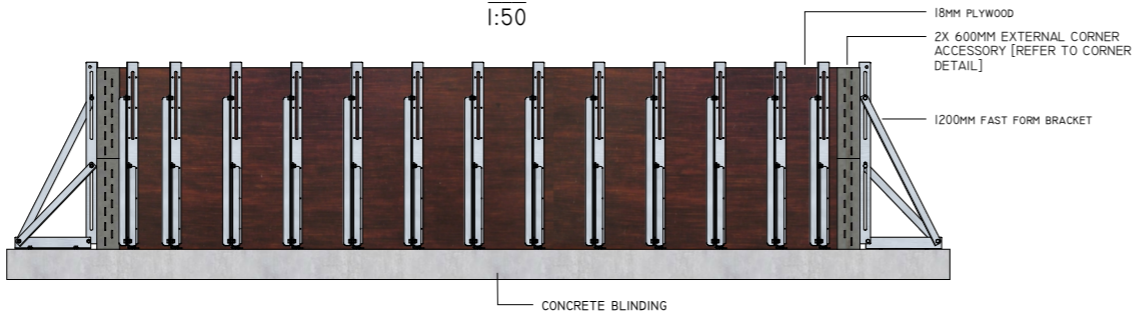

IMPORTANT:

CUSTOMER IS TO ENSURE THAT DURING POUR OPERATIONS CONCRETE IS PLACED IN AN EVEN MANNER PREVENTING THE IMBALANCE OF ANY FORCES. CONCRETE PLACEMENT IS TO BE CONTROLLED TO AVOID ADVERSE FORCES FROM HEAVING, SURGE AND IMPACT.

IMPORTANT:

ALL CONCRETE BOLTS TO BE INSTALLED ACCORDING TO THE PRODUCER'S TECHNICAL APPROVAL AND INSTALLATION GUIDES. (MAX. BOLT DIA 16MM)

IMPORTANT:
CONSULT YOUR TEMPORARY WORKS DEPARTMENT BEFORE USING THIS DESIGN FOR CONSTRUCTION.

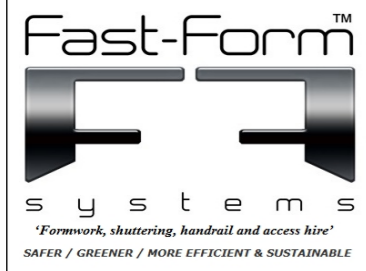

www.fastformsystems.com
info@fastformsystems.com
 South Tel: 0207 1481274
 North Tel: 08456 171152



Head Office:
 Unit 1
 Omega Business Park
 Estate Road 6
 Grimsby
 N.E.Lincs
 DN31 2TG

LEGAL NOTICE:

Fast Form™ is the Trade Mark of Fast-Form Systems Ltd and all copyright and intellectual property belong to the company. Fast Form™ is Patent granted, Patent number GB2508263 and is covered by a Worldwide Patent PCT/GB2014/052586 and further patent application No 1506126.0. Copyright or Trade Mark infringements will be prosecuted, If you see any similar bracket in operation without our name on it please send us an email to info@fastformsystems.com we offer a reward for all successful prosecutions.

Drawn by: M. Jankowski	Date: 06/07/16	Rev.: 0	Size: A3
Designed by: Tony White	Drawing no: xxxx-xxxx-xxxx		
Project: Fast Form Bracket System			
Drawing title: 1200mm Brackets - Base			